

T9-MH-XL-Indirect Sport Pendent (ISP)

The **MH-XL-ISP** mount fixture comes with **Patented Super Reflector Technology** which produces at least 20% more light than any other fixture. It is perfect for lighting all types of indoor tennis and sports facilities, including pools with white ceiling 16-100 feet high.

Description

T9 Ceramic Metal Halide indirect fixture is full bright in two minutes with two universal T9-30,000 hour lamps and two Integral 60,000 hour silent dimmable electronic ballasts.

- A 24" aluminum ribbed outer housing with high temperature polyester powder coat contains our Patented Super Reflector Technology with a Luminaire Efficacy Rating (LER) 95%.
- The fixture comes pre-wired and assembled. The ballasts are mounted in the bottom enclosure.
- Pendent mount with a included swivel ball cover allows fixture to move if hit.
- Standard voltage 200 to 480 volt.
- Available with motion sensors and dimming down to 50% for additional energy savings. When dimmed down 50% and motion is sensed, full bright in 10 seconds.
- Weight 34 lbs.
- For more light than a 1000 watt HID use the 630 watt **T9 MH-XL-Indirect Sport Pendent** as seen in photo.



DEER CREEK TENNIS CLUB, IL - 37% Energy Savings, T9 630 Watt - 25% MORE Light than 1000 watt fixtures!

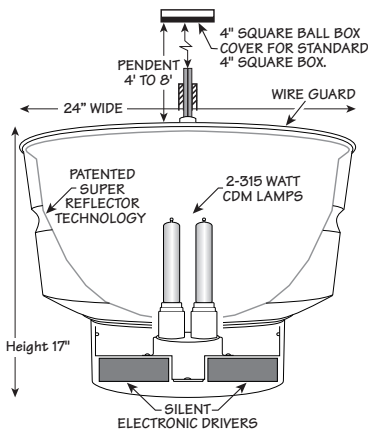

T9-MH-XL-ISP		Ordering Information: (Example: T9-MH-XL-ISP/630W/277V/P8/LI/WG)						
Lamp		Specify Voltage	Fixture Body		Pendent		Options	
T9-210W	T9	200 to 480	Aluminum	AL	6'	P6	Lamp Included	LI
T9-315W	T9				8'	P8	Wire Guard	WG
T9-420W	T9						Emergency Restrike	ER
T9-630W	T9							

FIXTURE WARRANTY

Best Lights, Inc. warranty fixtures to be free from defects in material and workmanship under normal use and service for a period of five (5) years from date of shipment. If found to be defective by us, we will replace the non-performing parts. Light bulbs and ballast on separate warranty.



T9 Lamp



PATENTED

www.bestlights.com